

APPLICATIONS AND SPECIFICATIONS

TYPICAL CABLE MOUNT APPLICATIONS

There is virtually no limit to the number of shock & vibration applications that can be solved using Cable Isolators. Listed below are some of the more common ones:

- Shipboard Electronics & Equipment
- Electronic Racks (single or multi-bay)
- Shipping Containers & Cases
- Equipment in Tanks & Tracked Vehicles
- Communication Shelters
- Rotating Equipment (Pumps, Generators, Compressors, etc...)
- Forging Hammers
- Avionics Equipment
- Aerospace
- Power Plants
- On and Off Road Transport
- Railway Equipment
- Applications Involving Extremes in Temperature
- Applications Involving Corrosive Environments

SHOCK & VIBRATION SPECIFICATIONS

The following are a few of the Specifications that Cable Isolated Equipment is routinely subjected to:

- MIL-S-901 - Covers Naval Shipboard shock testing requirements
- MIL-STD-167 - Covers Naval Shipboard vibration testing requirements
- MIL-STD-810 - Covers environmental test methods for military equipment
- MIL-E-5400 - Covers requirements for design and manufacture of airborne electronic equipment
- MIL-T-5422 - Testing specification for MIL-E-5400

APPLICATIONS AND SPECIFICATIONS

DEFINITION OF LOADING MODES

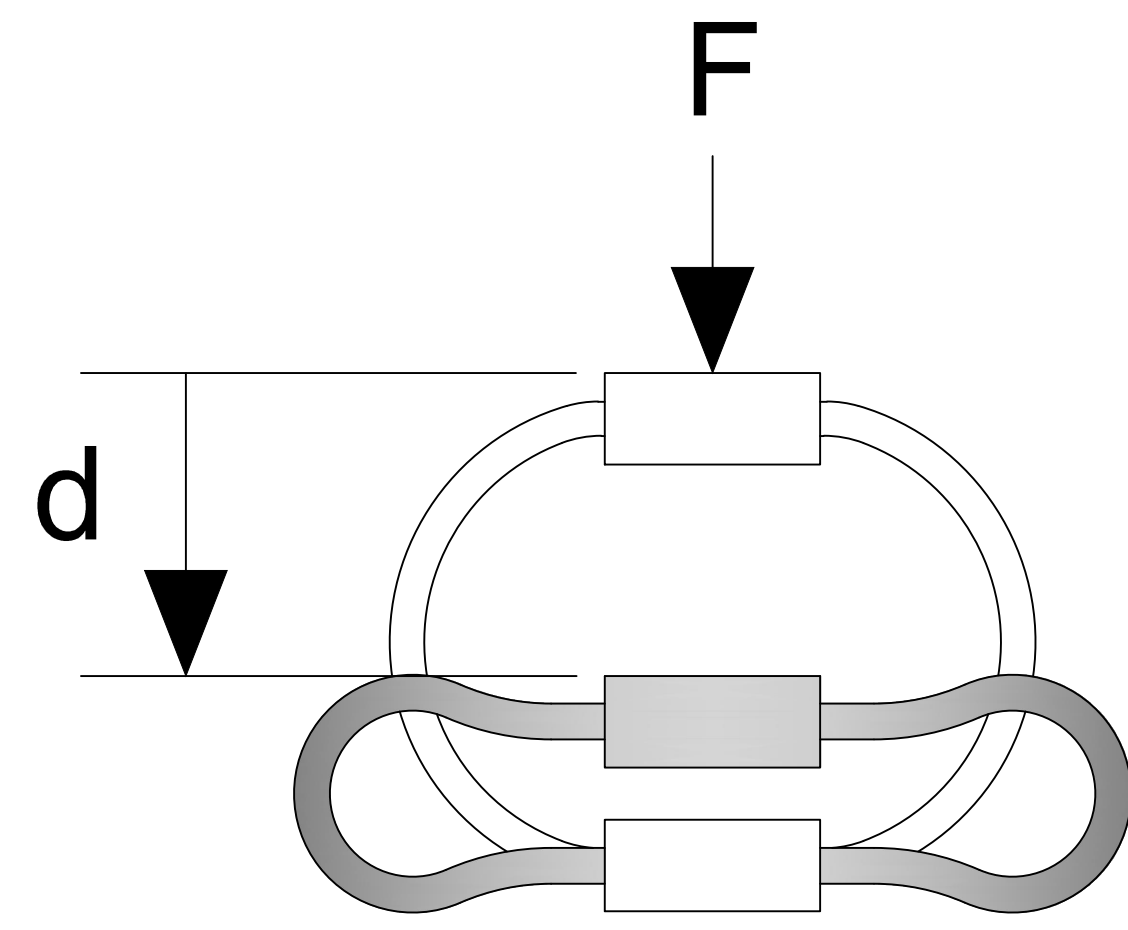

COMPRESSION

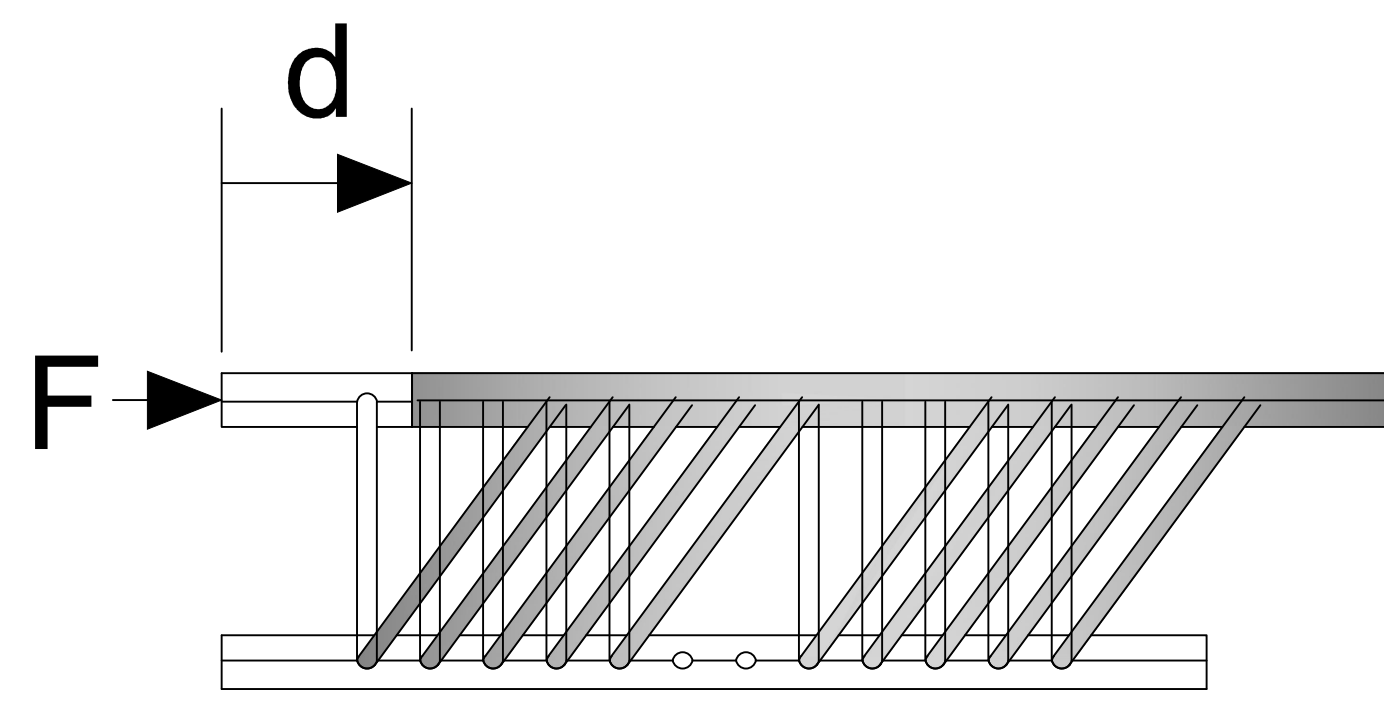

SHEAR

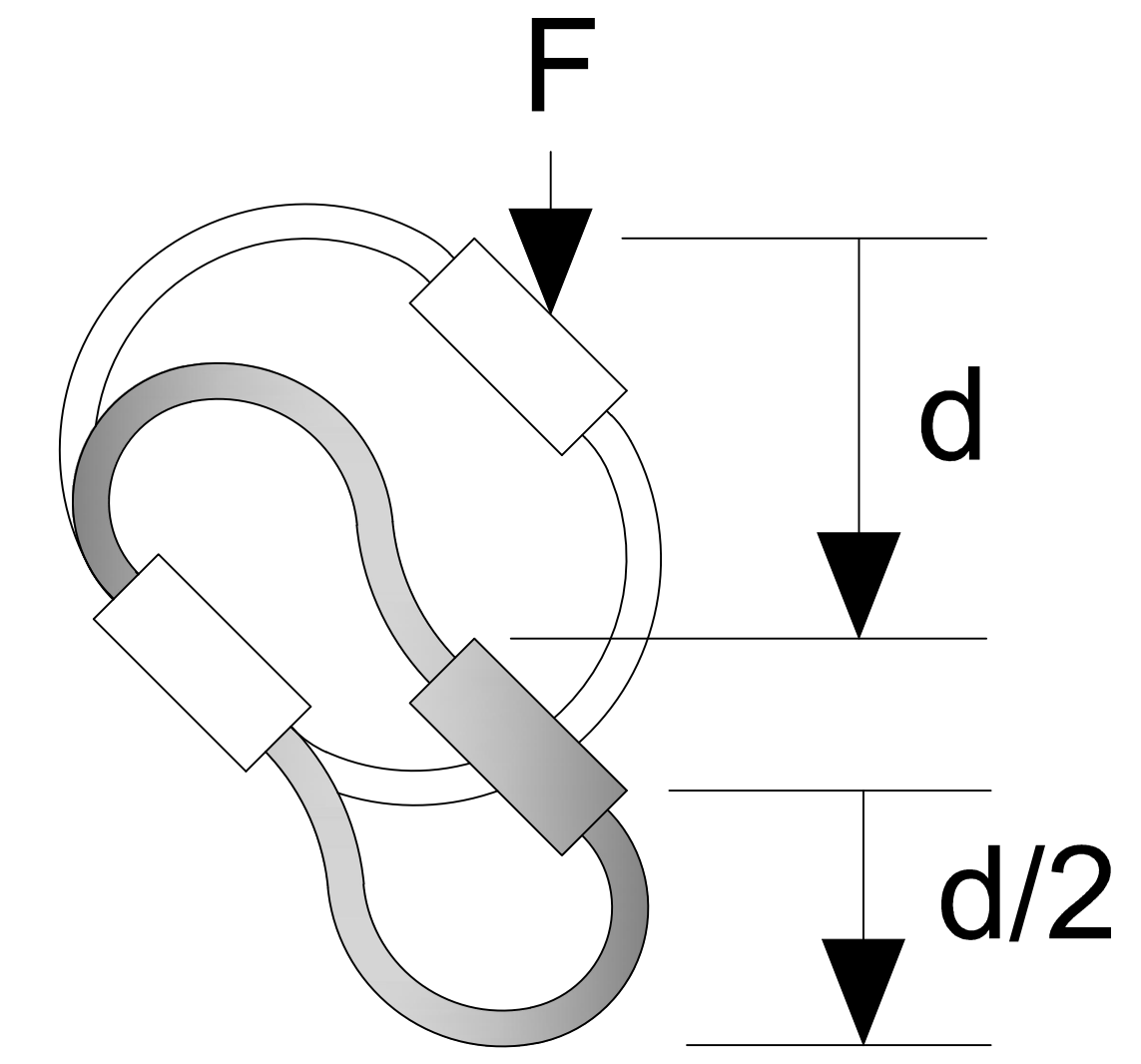

45° COMPRESSION/ROLL

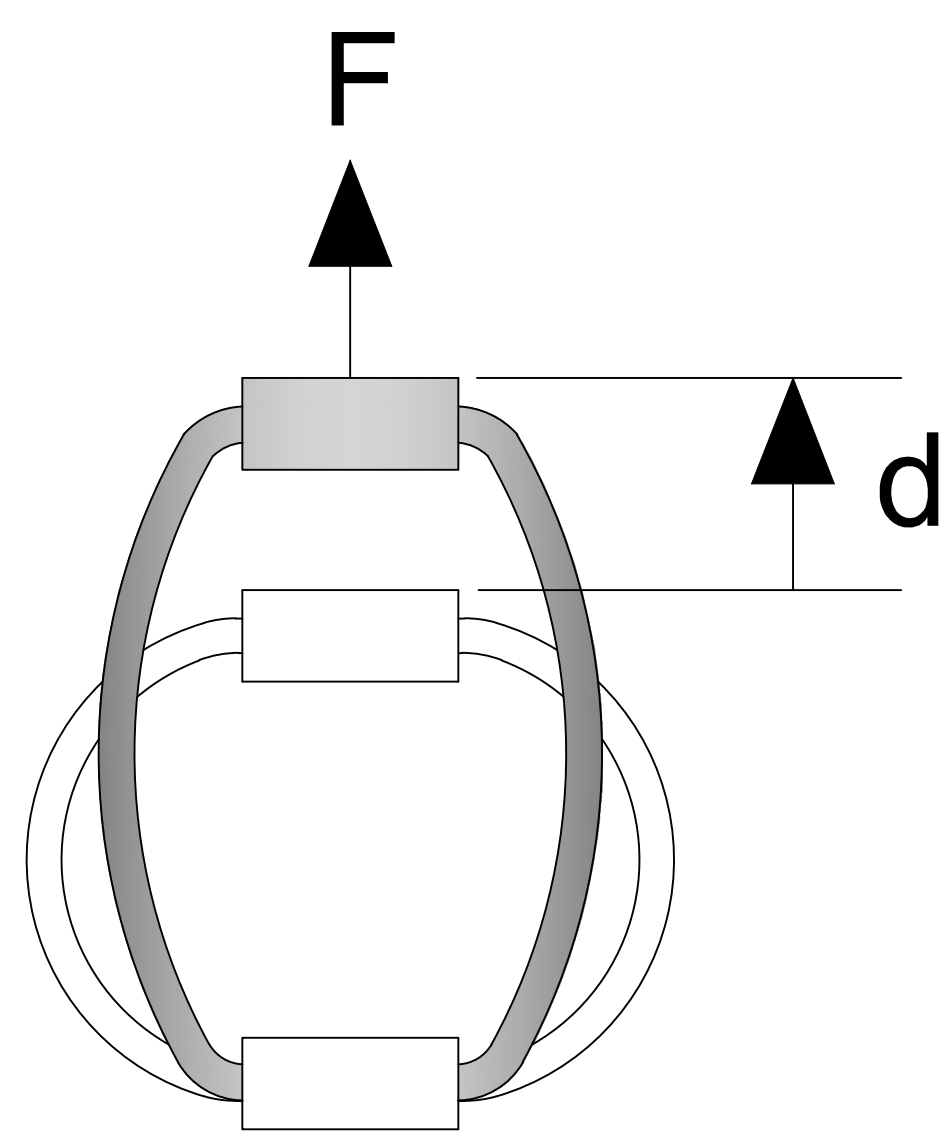

TENSION

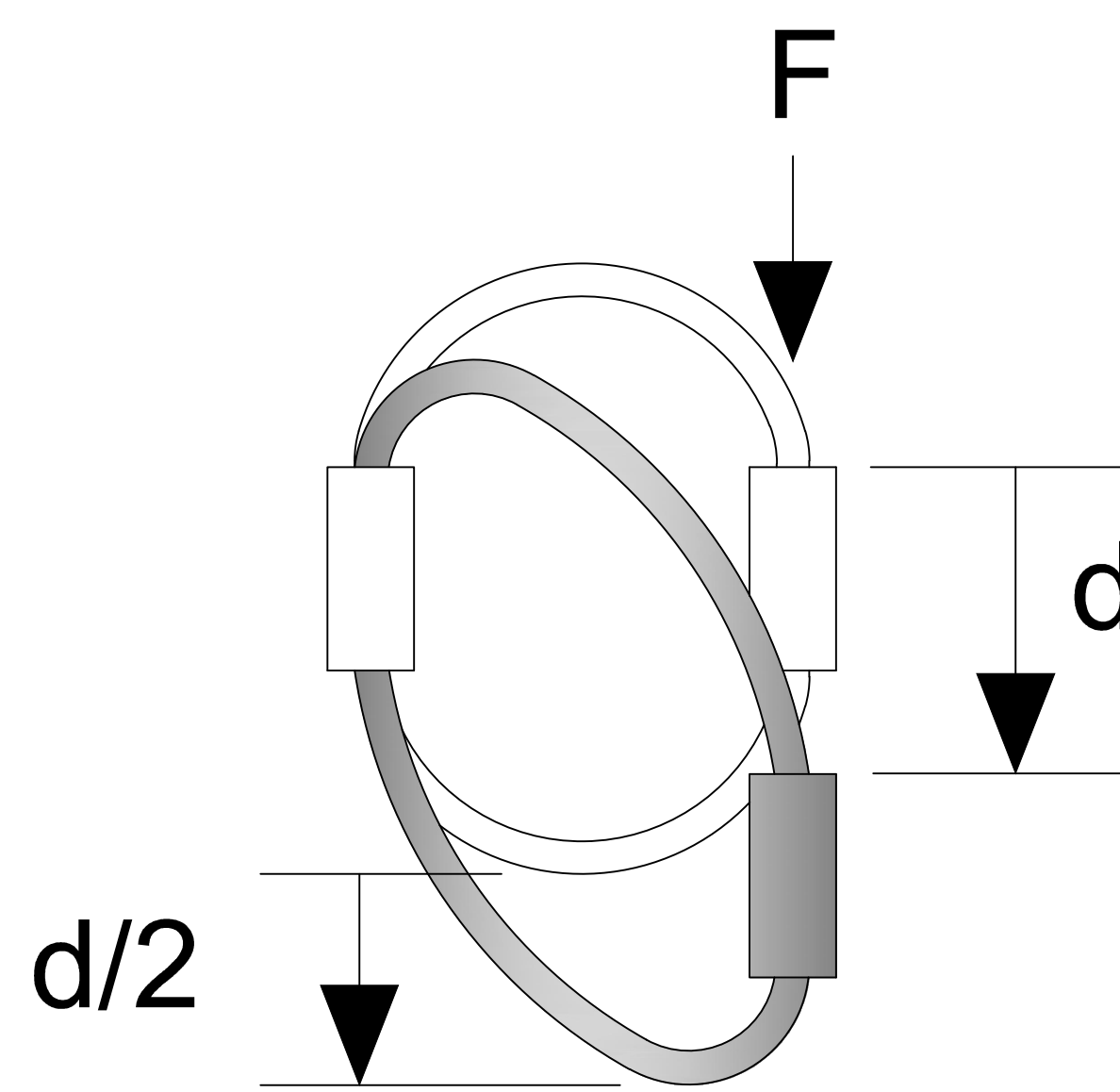

ROLL

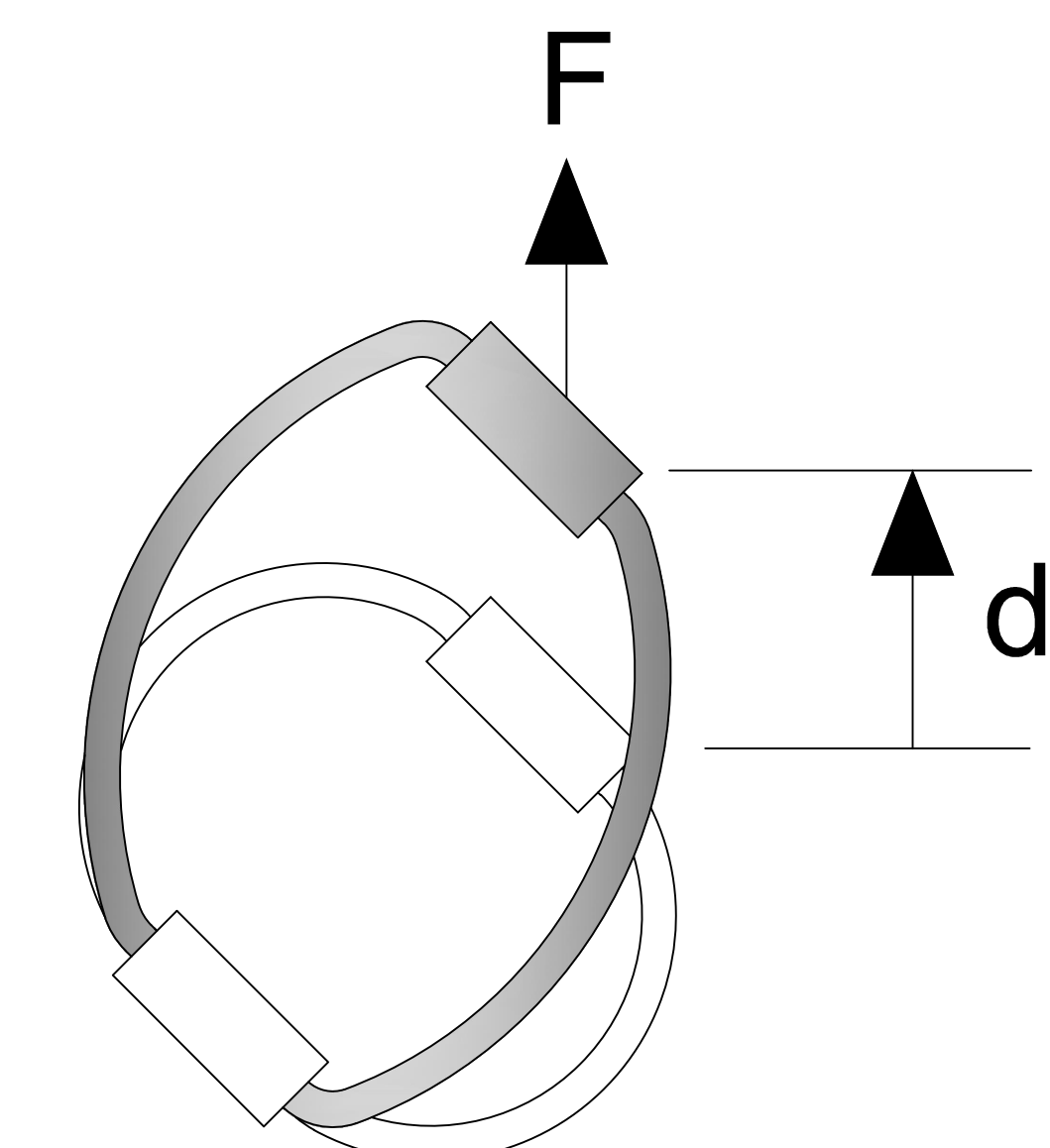

45° TENSION/ROLL

Load vs. deflection data for each of the different load modes can be found on the Isolator Data Sheets.

MOUNTING HOLE OPTIONS

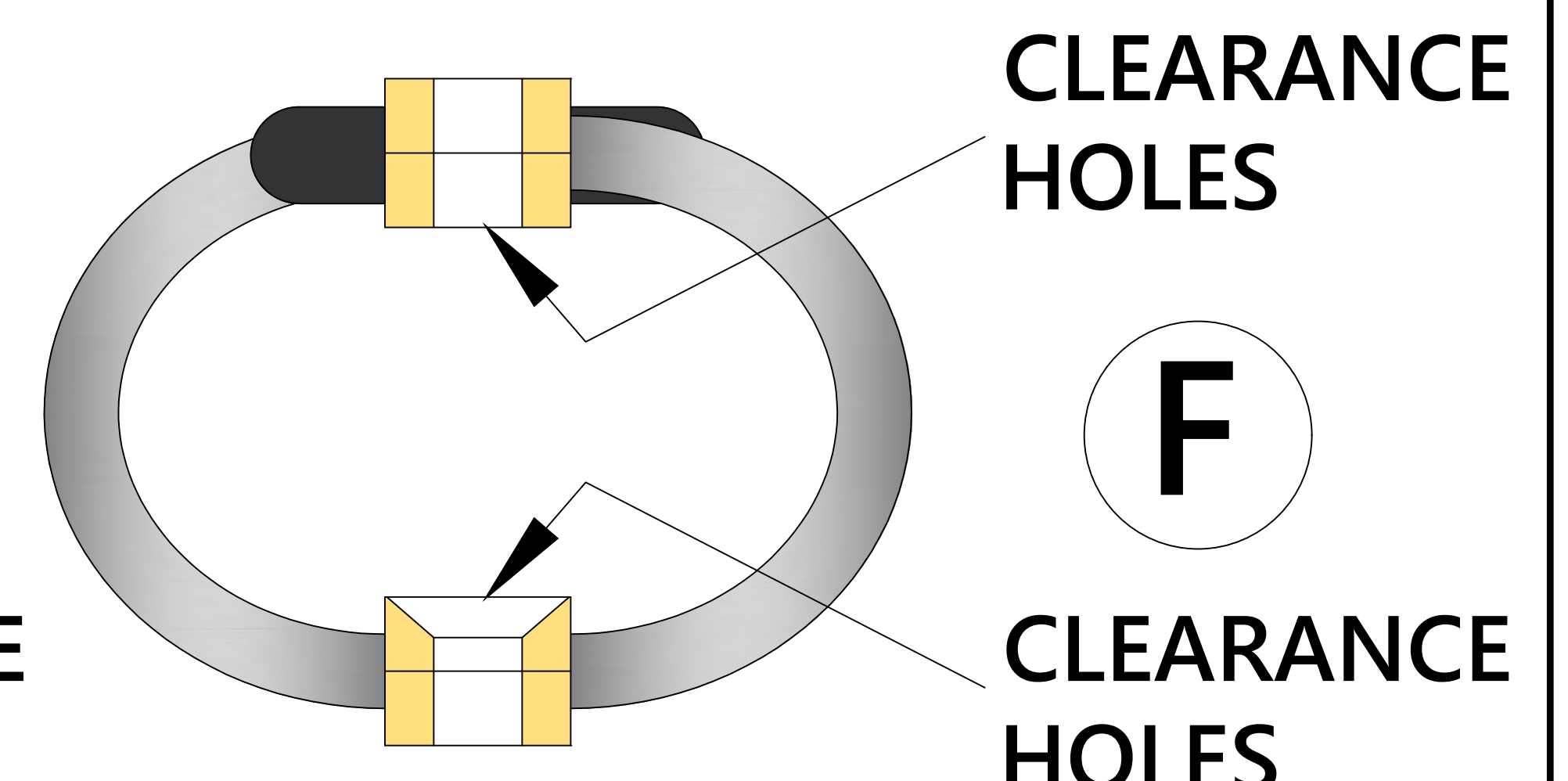
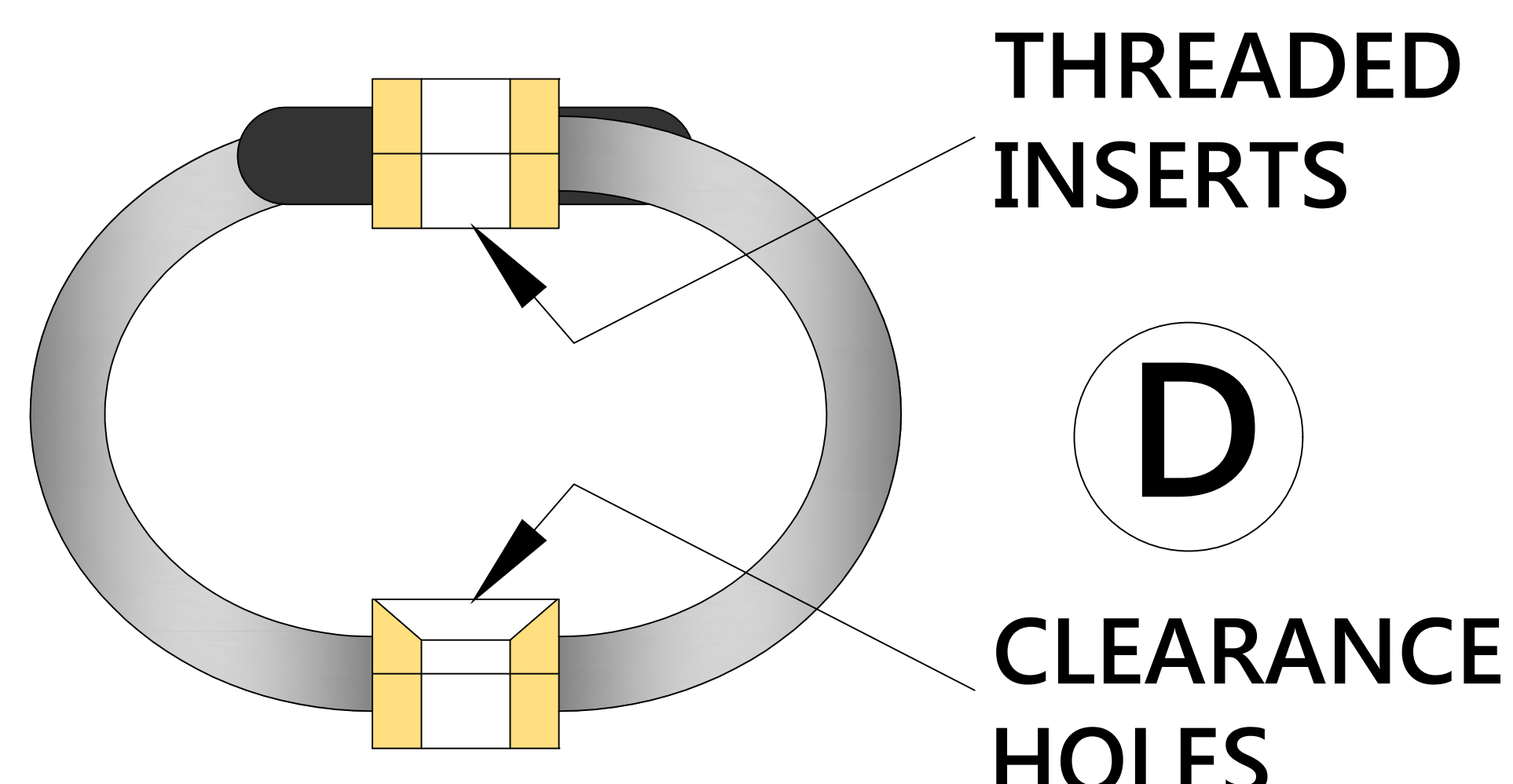
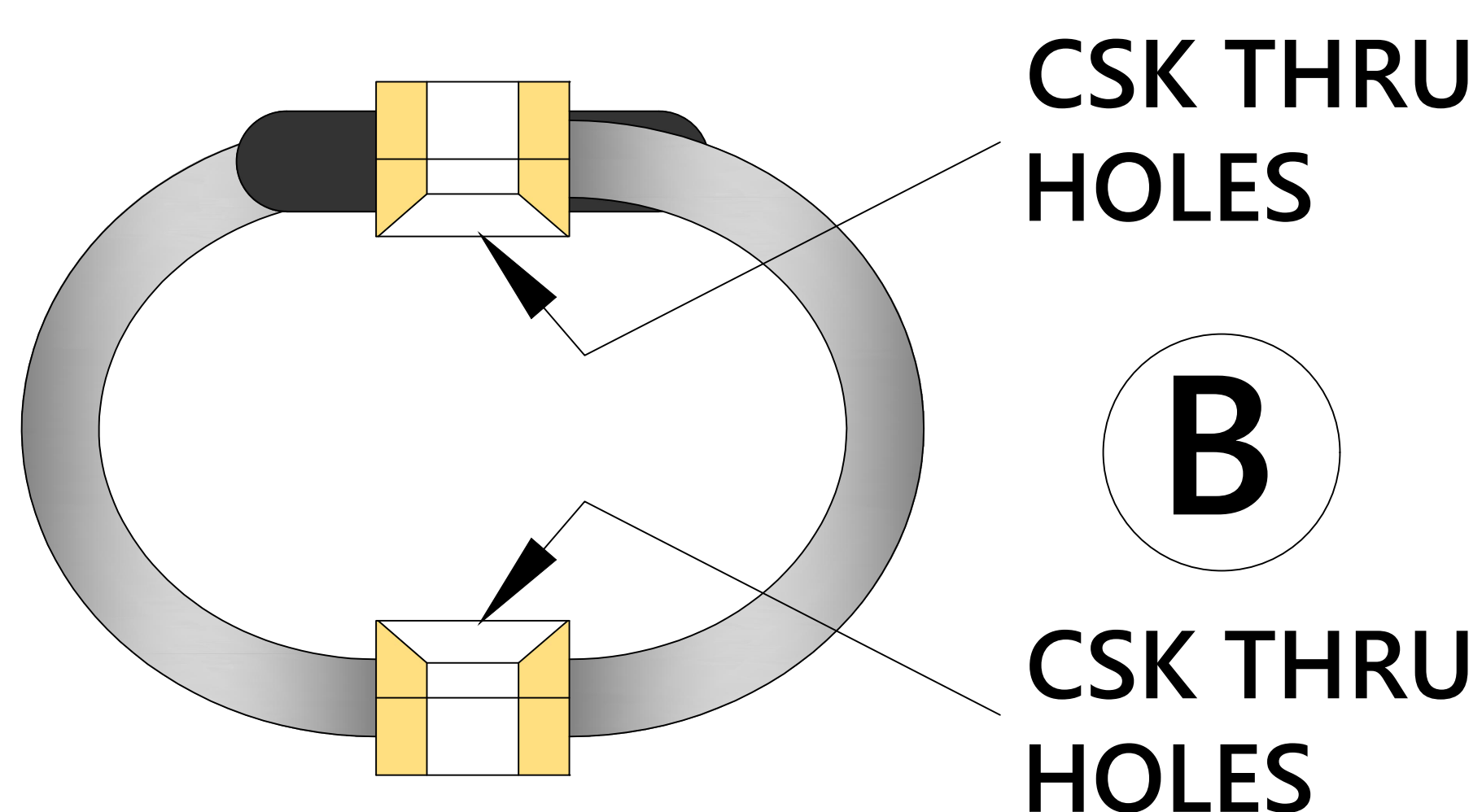
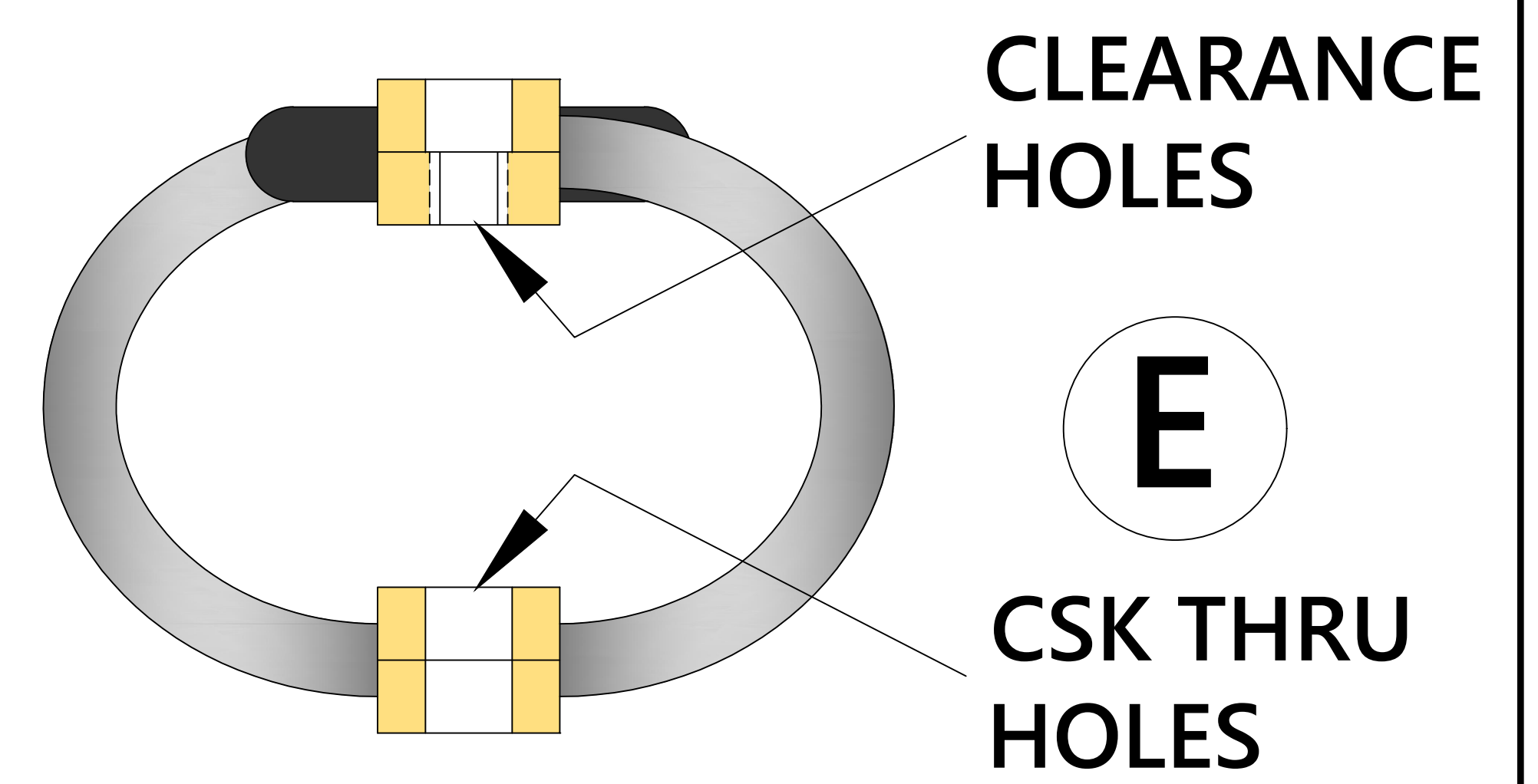
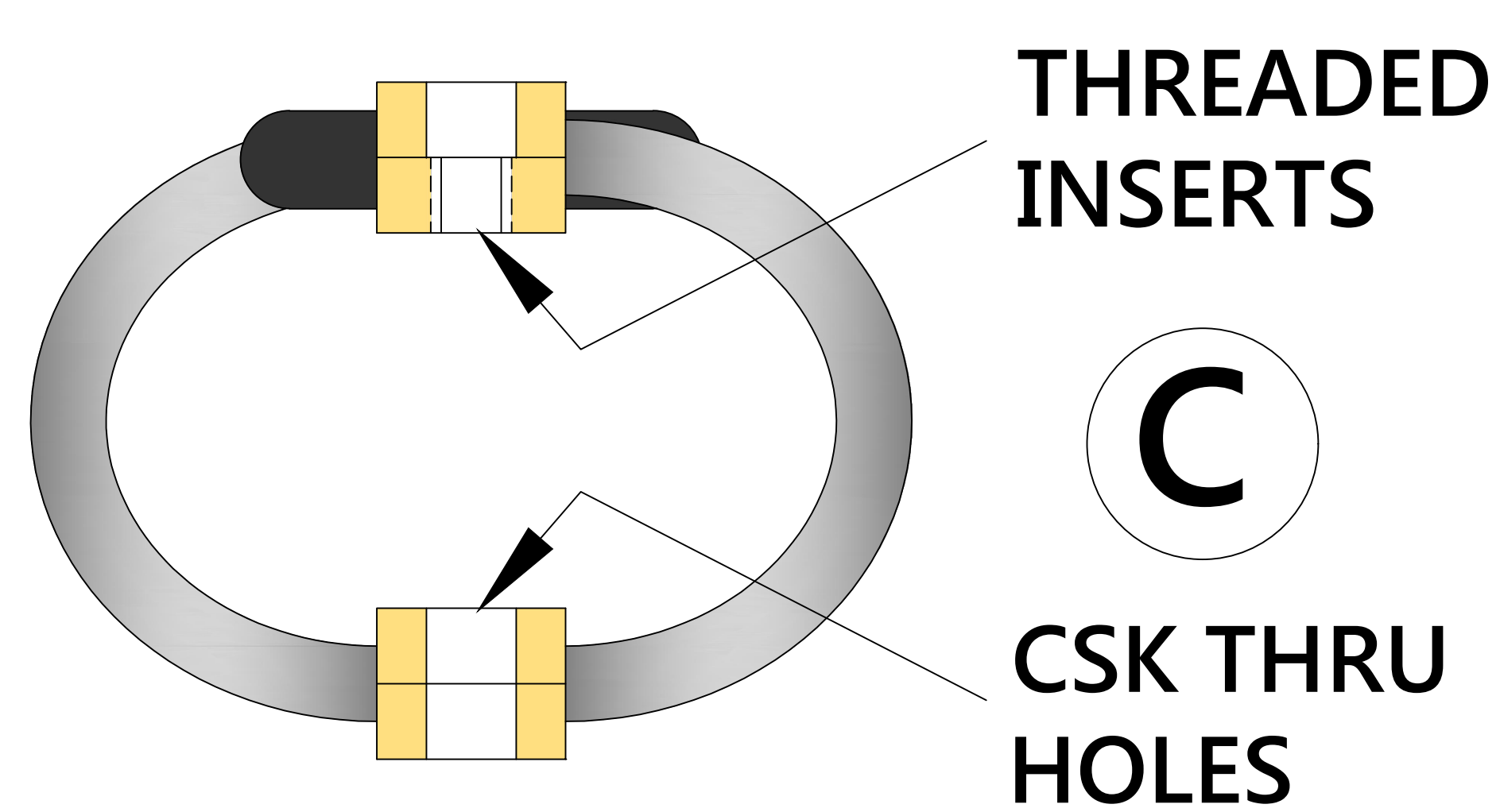
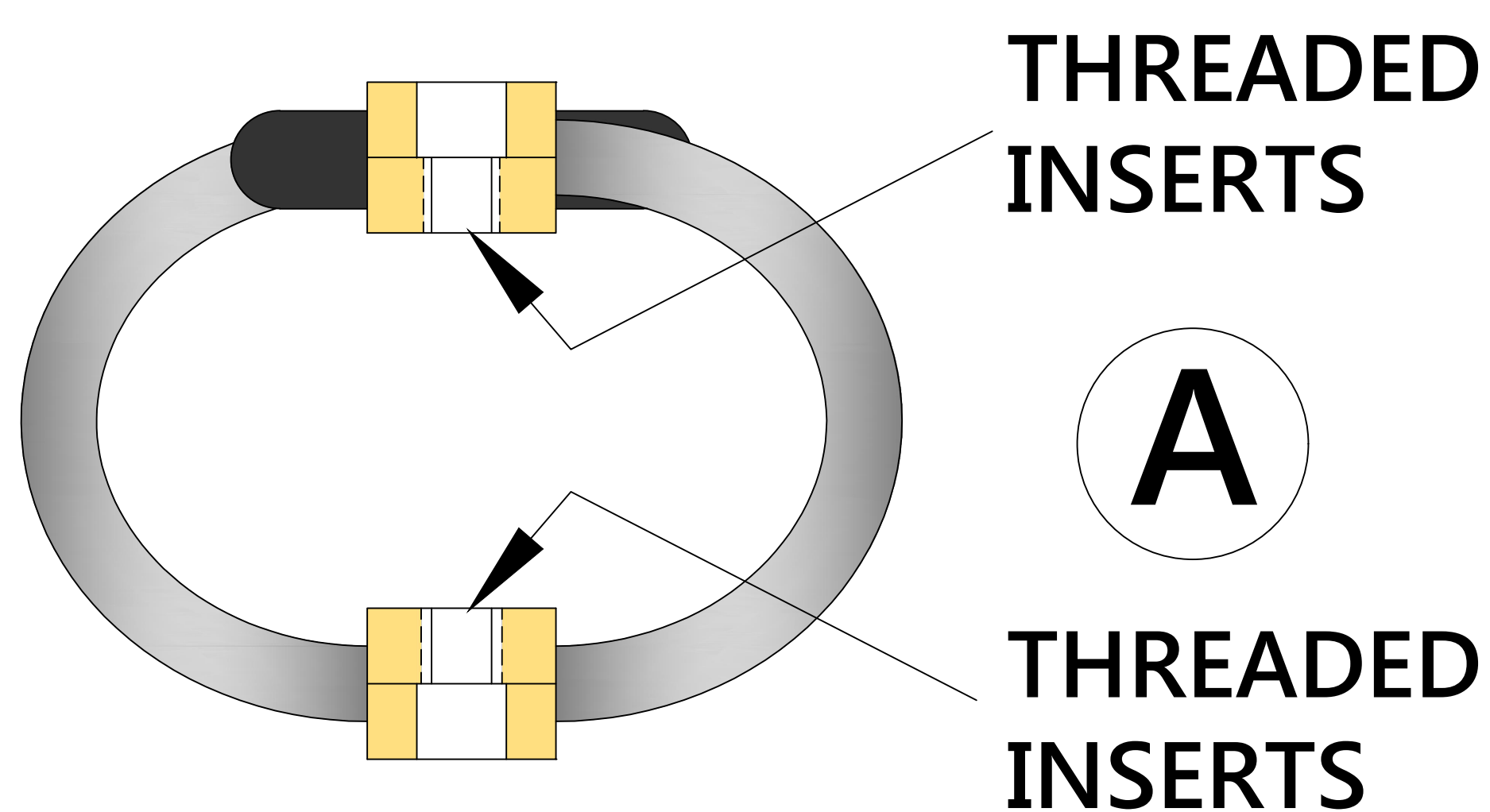

See Isolator Data Sheets for detailed information regarding mounting holes.

APPLICATIONS AND SPECIFICATIONS

GUIDELINES FOR INSTALLATION

The many mounting hole options offered with IDC isolators makes installing them simple. In order to facilitate installation and insure successful performance, certain guidelines should be followed when selecting isolator mounting holes:

Plain clearance holes (-F configuration) should generally be avoided unless other mounting hole options are not feasible. This is especially true for applications involving shock where large displacements can be expected. The bolt heads can severely reduce the isolator's available sway space. In addition, installation of the -F configuration can prove difficult for low profile isolators.

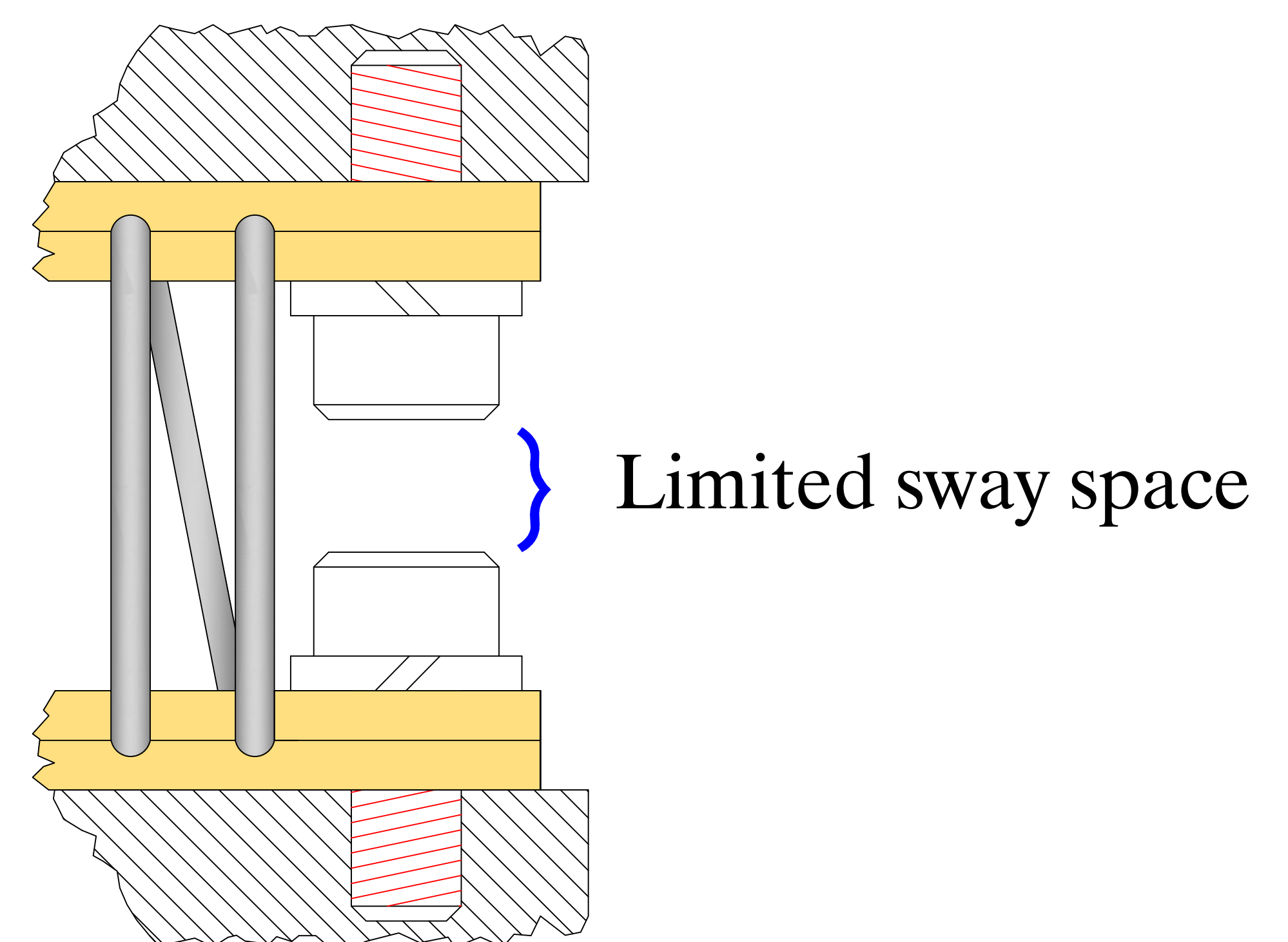

The -C configuration (combination countersunk thru holes & threaded inserts) usually provides the easiest installation. First bolt the isolator in place using the top holes as a clearance for an Allen wrench. Then lower the equipment down and bolt to top of isolator.

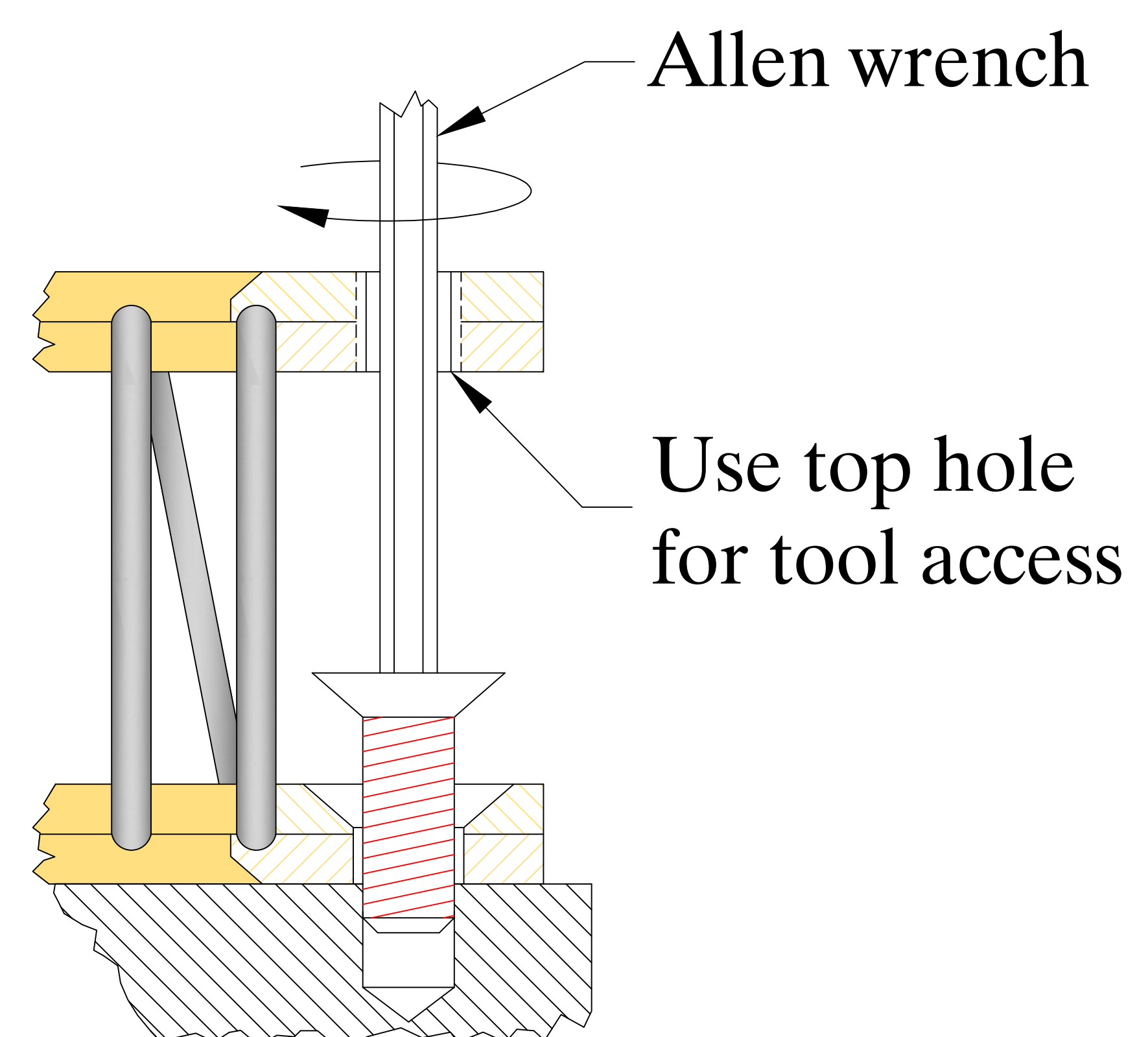

When selecting hardware for countersunk or plain clearance hole configurations, be sure that the length of the bolt does not exceed the distance between the inner bars. This distance is easily calculated by subtracting the combined bar thickness from the overall height.

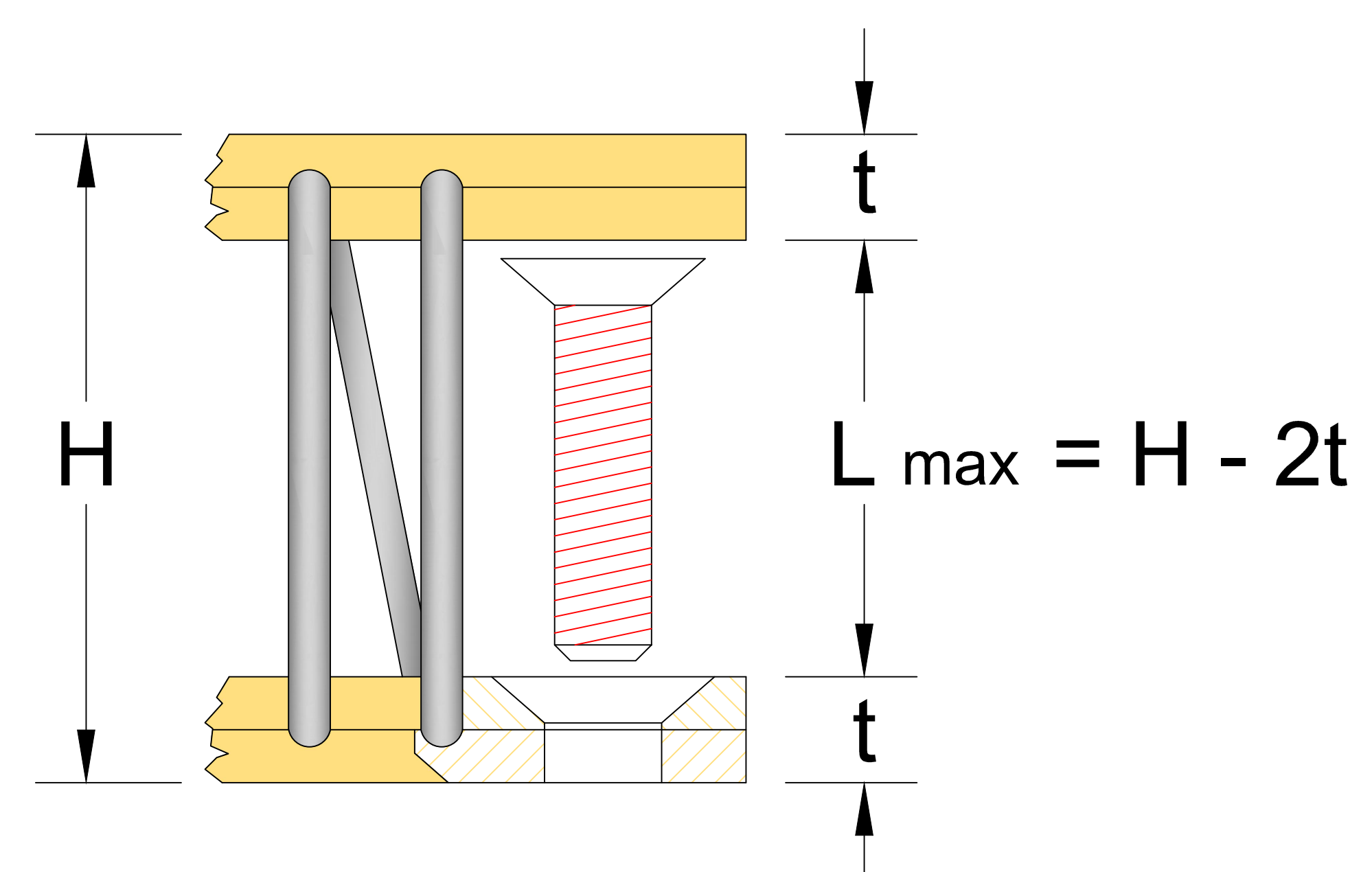

APPLICATIONS AND SPECIFICATIONS

GUIDELINES FOR INSTALLATION (CONT.)

When specifying isolators with threaded inserts, limit protrusion of bolt to approximately two threads into the space between the bars. This is especially important for applications involving large displacements. A protruding bolt can significantly reduce the available sway space.

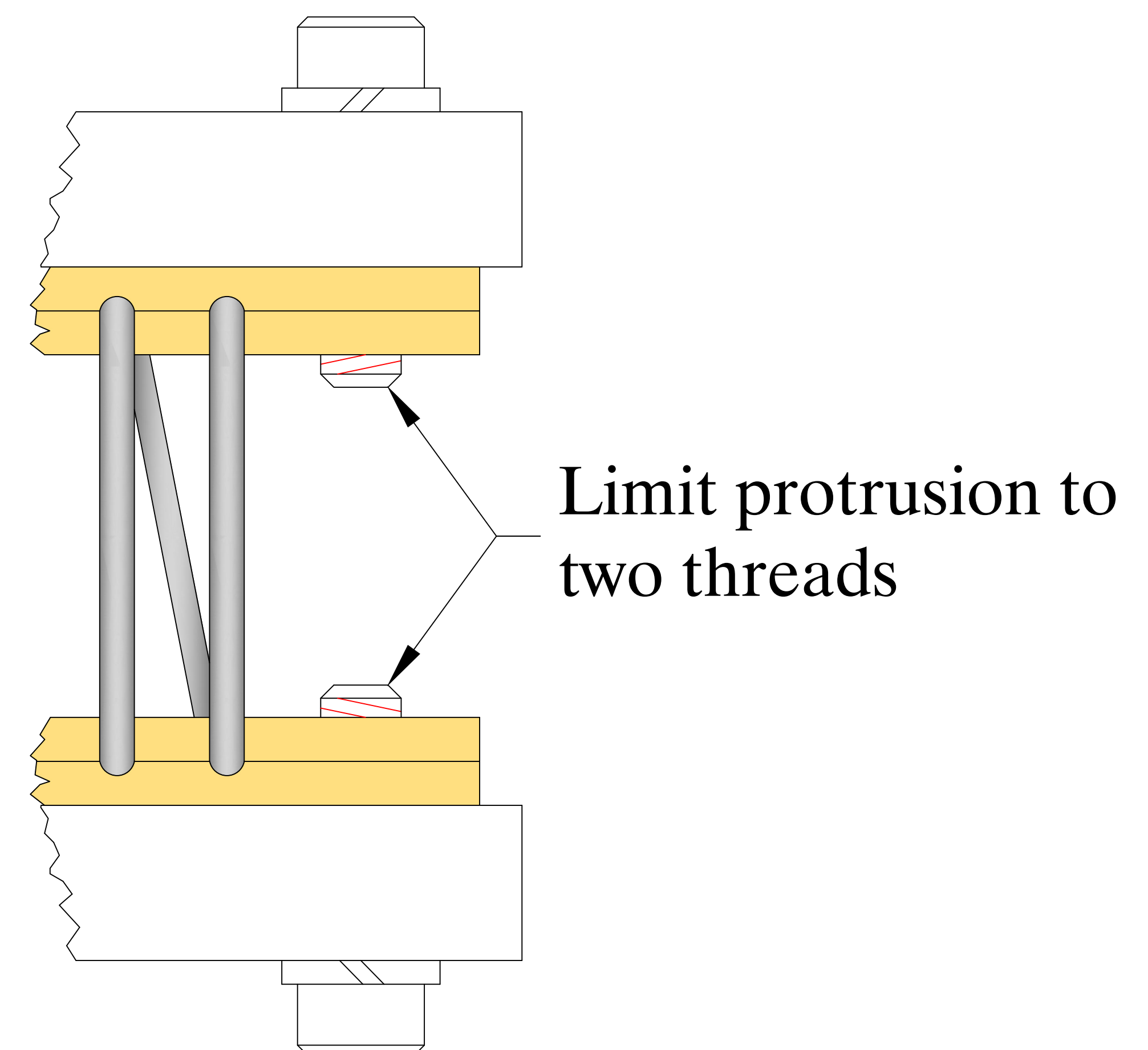

Use proper amount of tightening torque when installing isolators. The amount of torque will depend on the size and material of the installation hardware. Over-tightening may result in damaging threaded inserts; Under-tightening may result in hardware becoming loose during conditions of shock & vibration. This is especially true for the side of the isolator subjected to vibration/shock. Use of Loctite or other locking features, is recommended to prevent loosening of hardware. All IDC isolators are available with locking inserts.

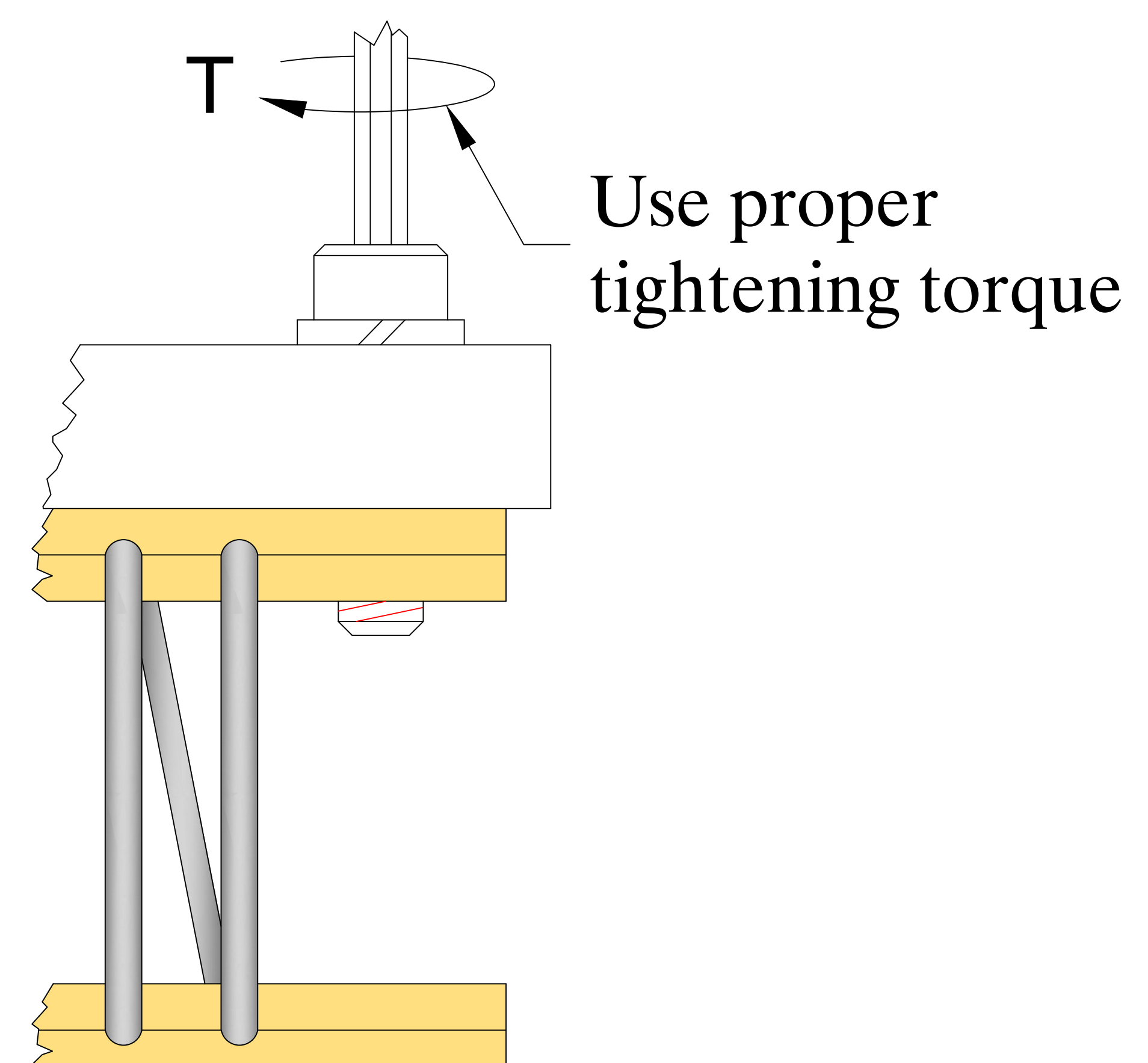

For applications where installation is difficult, the use of transition plates may become necessary. A secondary benefit of transition plates is they provide structural rigidity to the equipment and/or mounting surfaces. See section under "Specials & Systems" for examples.

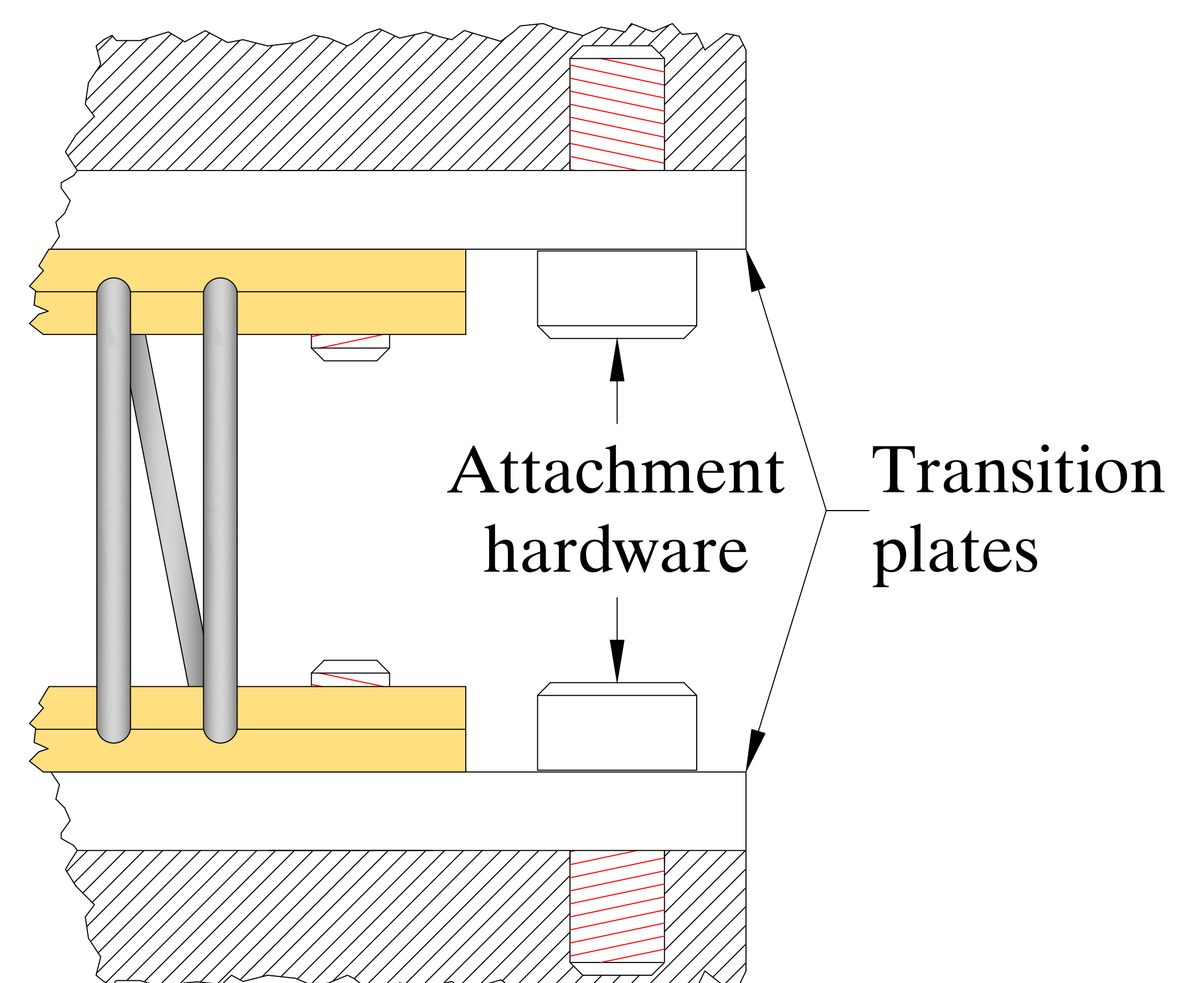

Feel free to contact us if you have any questions or concerns regarding the installation of IDC Isolators.