

3/16" DIAMETER CABLE

HELICAL ISOLATOR

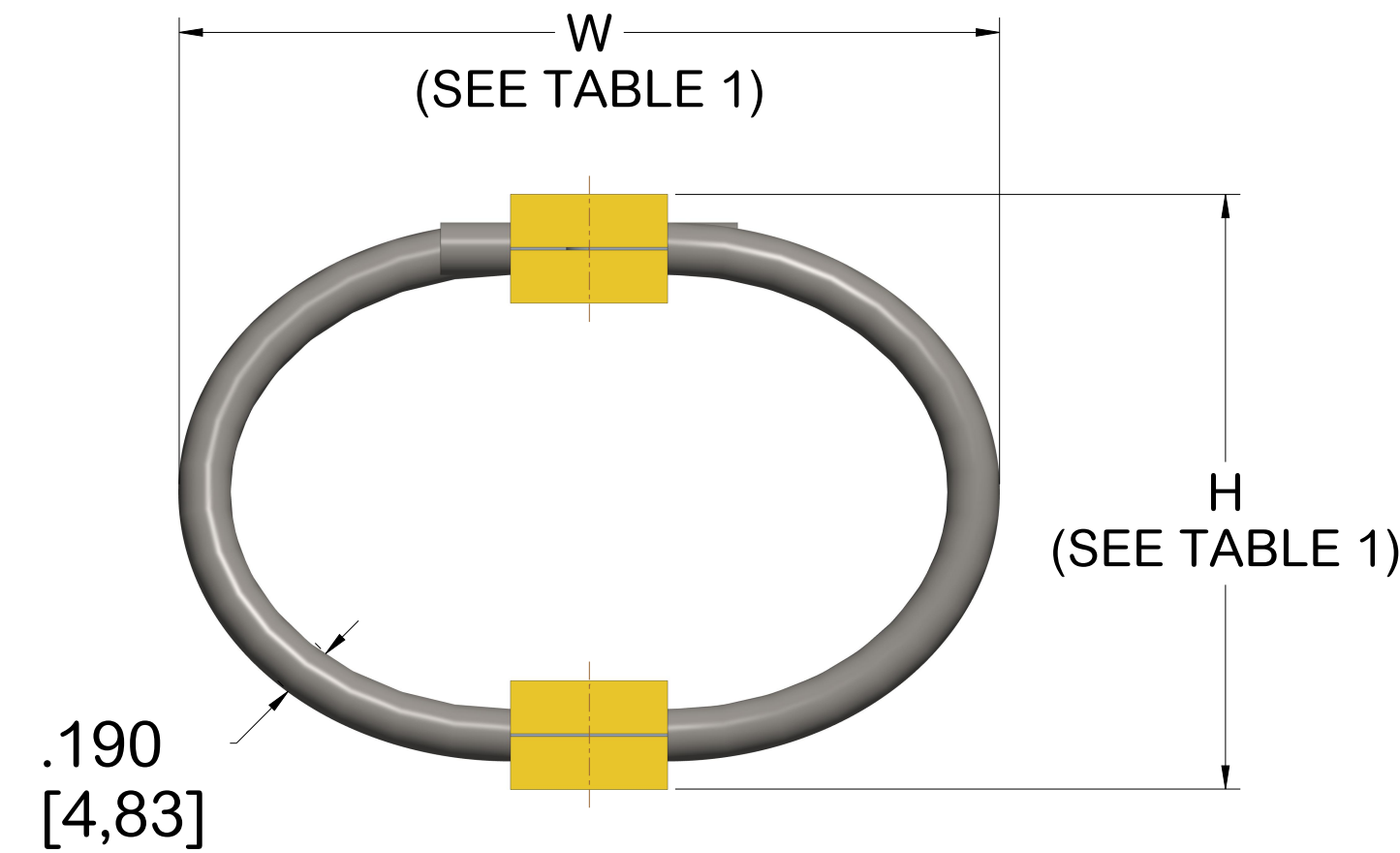
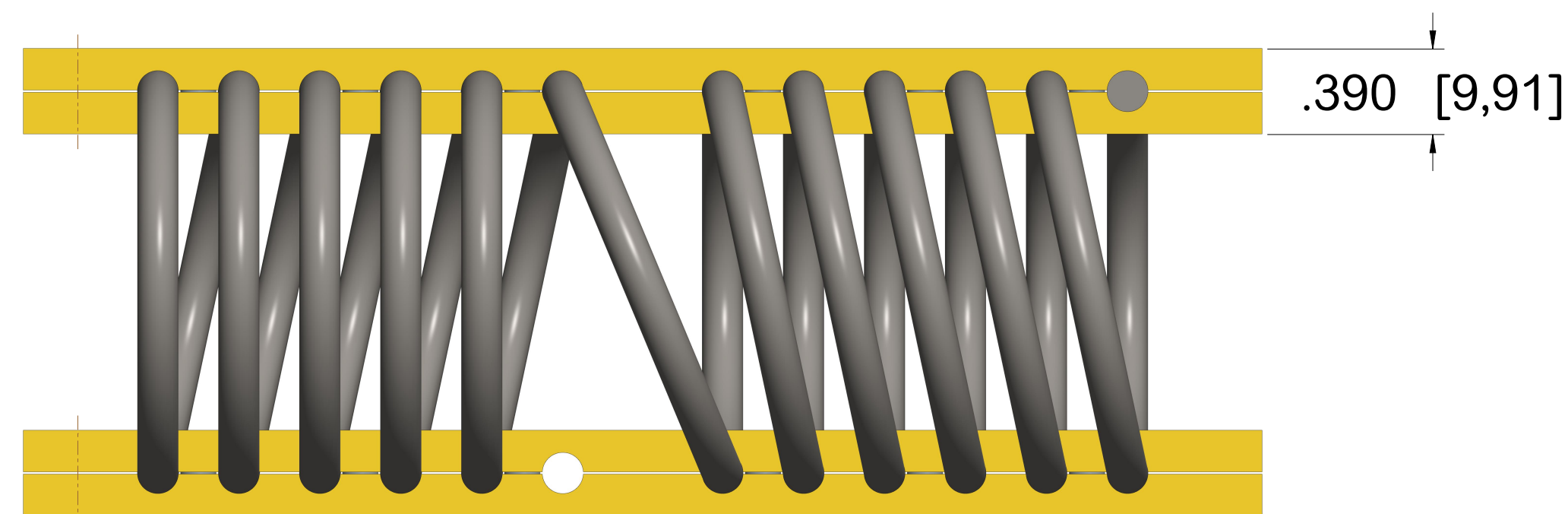
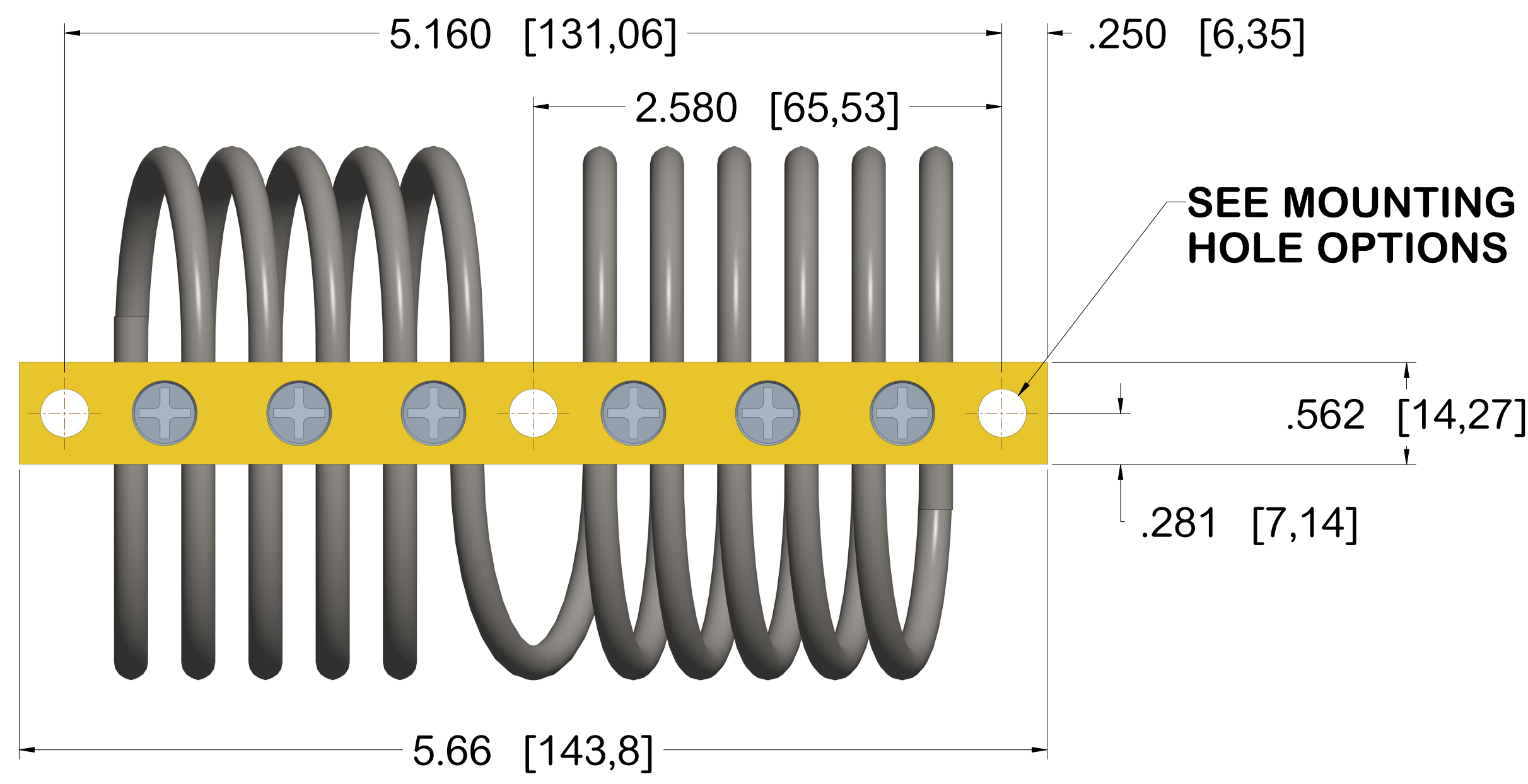

PART NUMBER	DIMENSIONS in(mm)		ISOLATOR WEIGHT oz (gms)	COMPRESSION			SHEAR/ROLL (AVG)		
	H	W		KV (VIBE) (lbs/in)	KS (SHOCK) (lbs/in)	MAX. DEFLECT.(in)	KV (VIBE) (lbs/in)	KS (SHOCK) (lbs/in)	MAX. DEFLECT.(in)
M6A-200-11-[]	2.00 (50,8)	2.28 (57,9)	8.6 (244)	462	330	1.10	152	166	1.00
M6A-206-1A-[]	2.06 (52,3)	2.50 (63,5)	8.9 (253)	375	273	1.05	104	142	1.05
M6A-213-11-[]	2.13 (54,1)	2.94 (74,7)	9.4 (267)	259	182	1.10	76	102	1.10
M6A-219-11-[]	2.19 (55,6)	3.19 (81,0)	10.2 (289)	181	132	1.15	64	84	1.15
M6A-245-11-[]	2.45 (62,2)	3.45 (87,6)	10.6 (301)	168	109	1.60	38	63	1.60
M6A-320-11-[]	3.20 (81,3)	4.20 (106,7)	12.8 (363)	87	49	2.20	18	34	2.20

NOTES, FEATURES, MATERIALS/FINISHES

NOTES:

- ° ALL DIMENSIONS ARE FOR REFERENCE ONLY
- ° ALL DIMENSIONS IN PARENTHESIS ARE METRIC (mm)
- ° SPECIALS AVAILABLE UPON REQUEST (MATERIALS, SIZE, MOUNTING HOLES, FINISH, ETC...)
- ° ADD 4.15oz (.12kg) TO ISOLATOR WEIGHT FOR ALL STAINLESS STEEL VERSIONS

FEATURES:

- ° RUGGED ALL METAL CONSTRUCTION
- ° UNEQUALLED TEMP. RANGE: -200 ° F TO 500 ° F
- ° THREE AXIS CAPABILITY (6 DOF)
- ° FAIL SAFE CONSTRUCTION
- ° HIGH DAMPING: C/Cc .15-.20
- ° LONG LIFE AND MAINTENANCE FREE

MATERIALS/FINISHES:

- ° CABLE: 300 SERIES SS PER MIL-W-83420 OR RR-W-410
- ° SCREWS: 300 SERIES SS PER MS51959-42
- ° INSERTS: 300 SERIES SS (ALUM BARS ONLY)
- ° RETAINER BARS: SEE BELOW

MODEL NUMBER EXAMPLE

M6A - 219 - 11 - - E

MOUNTING HOLES

- ° SEE MOUNTING HOLE OPTIONS.
- ° ADD 'M' TO END OF P/N FOR METRIC MOUNTING HOLES.
- ° ADD 'L' TO END OF P/N FOR LOCKING INSERTS. (N/A FOR SS BARS).

BAR MATERIAL/FINISH

- ° []= 6061-T6 ALUM ALLOY/CHEM FILM IAW MIL-DTL-5541, TYPE II, CLASS III.
- ° [H]= 6061-T6 ALUM ALLOY/ANODIZED IAW MIL-A-8625, TYPE II, CLASS I.
- ° [S]= 300 SERIES SS/PASSIVATED IAW ASTM A967.

NO. OF LOOPS

- ° ISOLATOR SPRING RATES ARE DIRECTLY PROPORTIONAL TO NO. OF CABLE LOOPS.

MODEL SIZE

- ° BASED ON ISOLATOR HEIGHT.

SERIES

- ° CABLE DIAMETER IN 32NDS.

MOUNTING HOLE OPTIONS

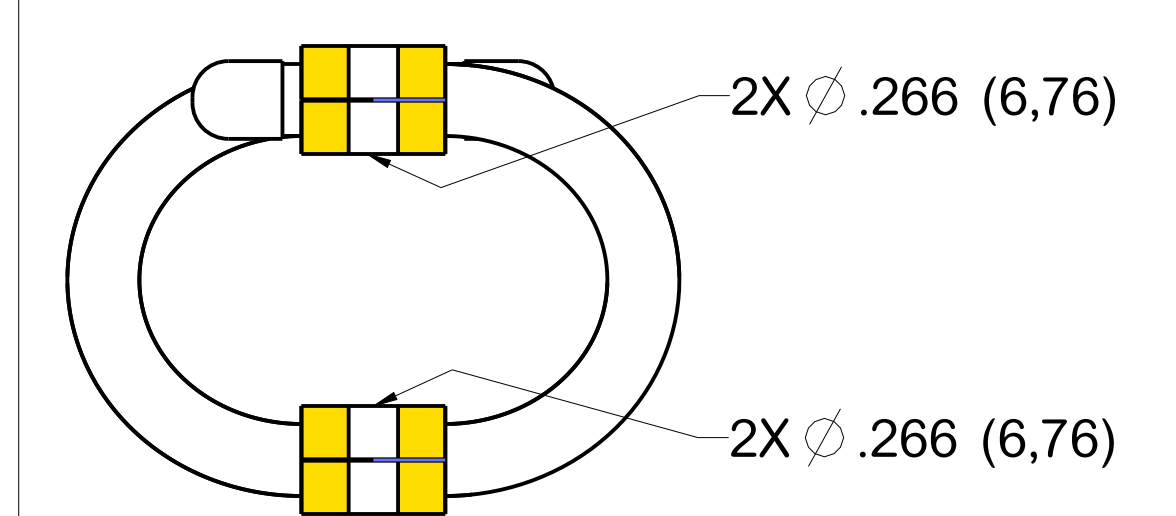
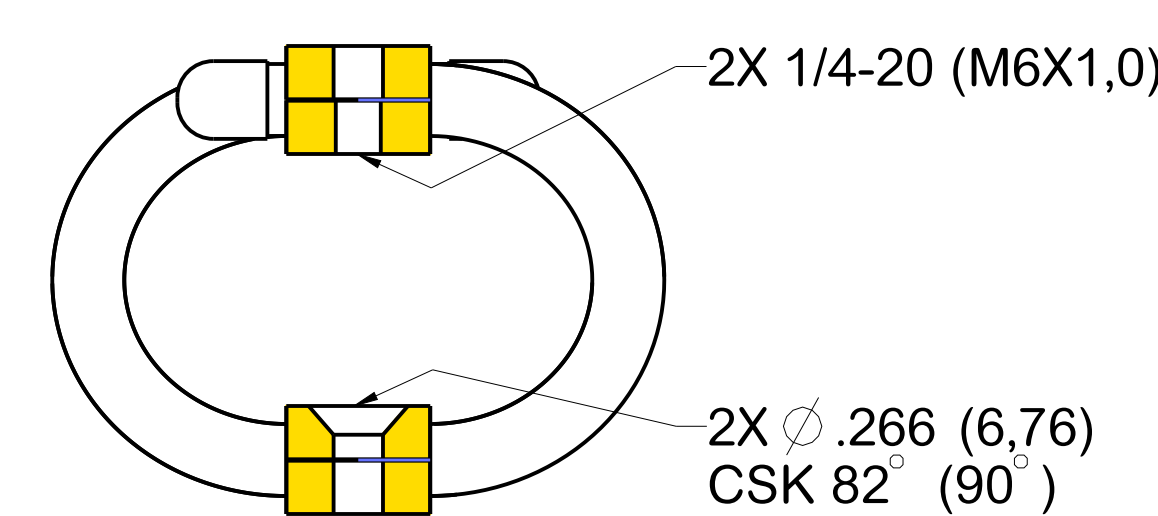
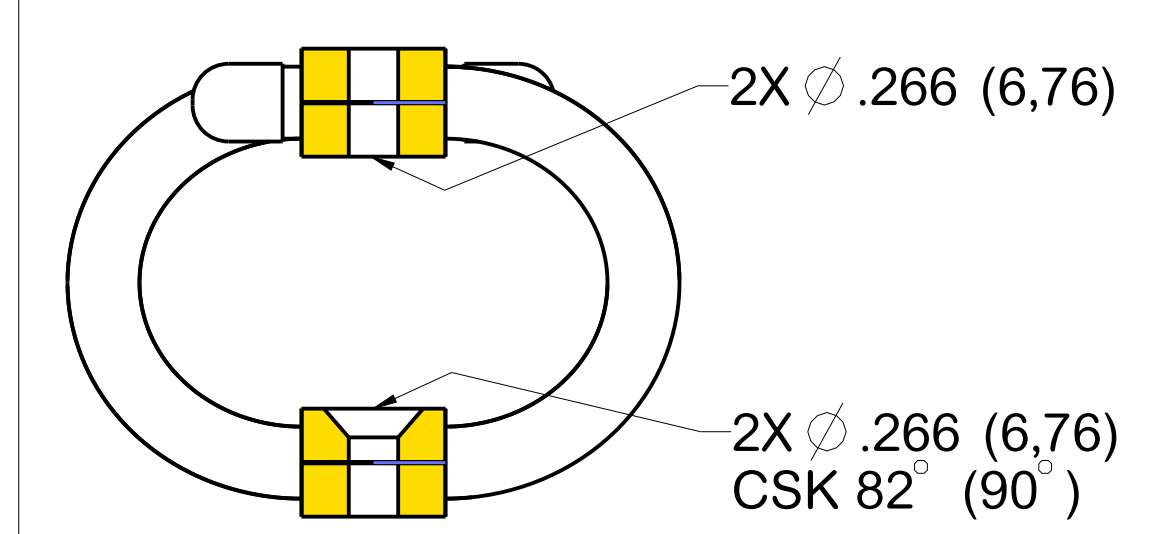
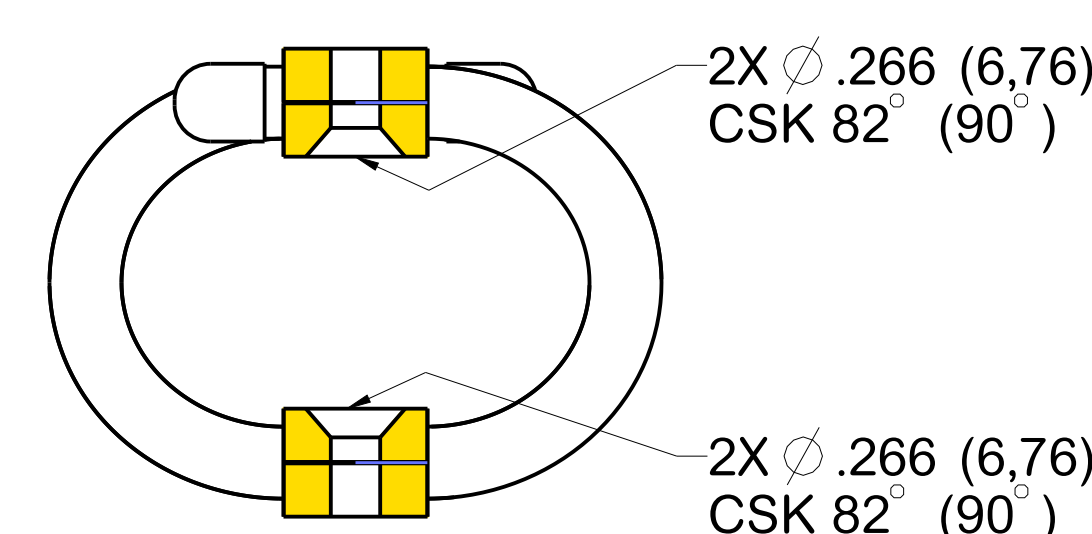
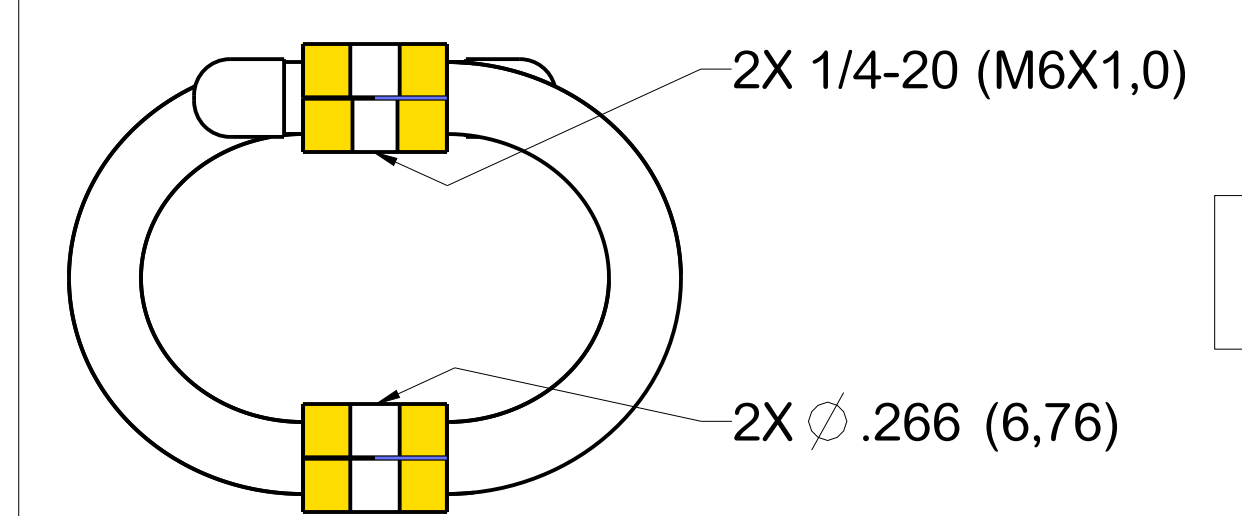
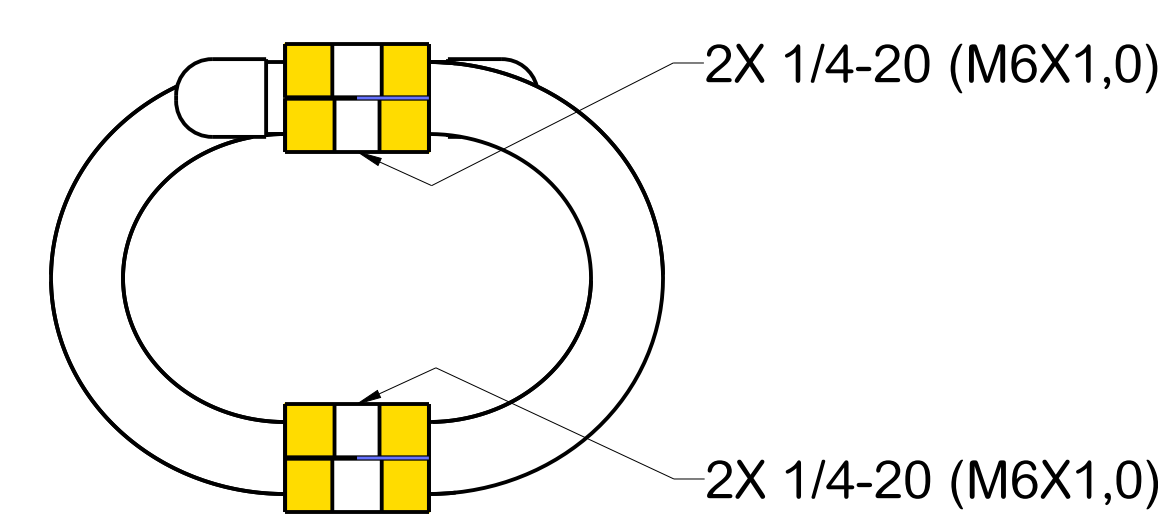

3/16" DIAMETER CABLE

HELICAL ISOLATOR

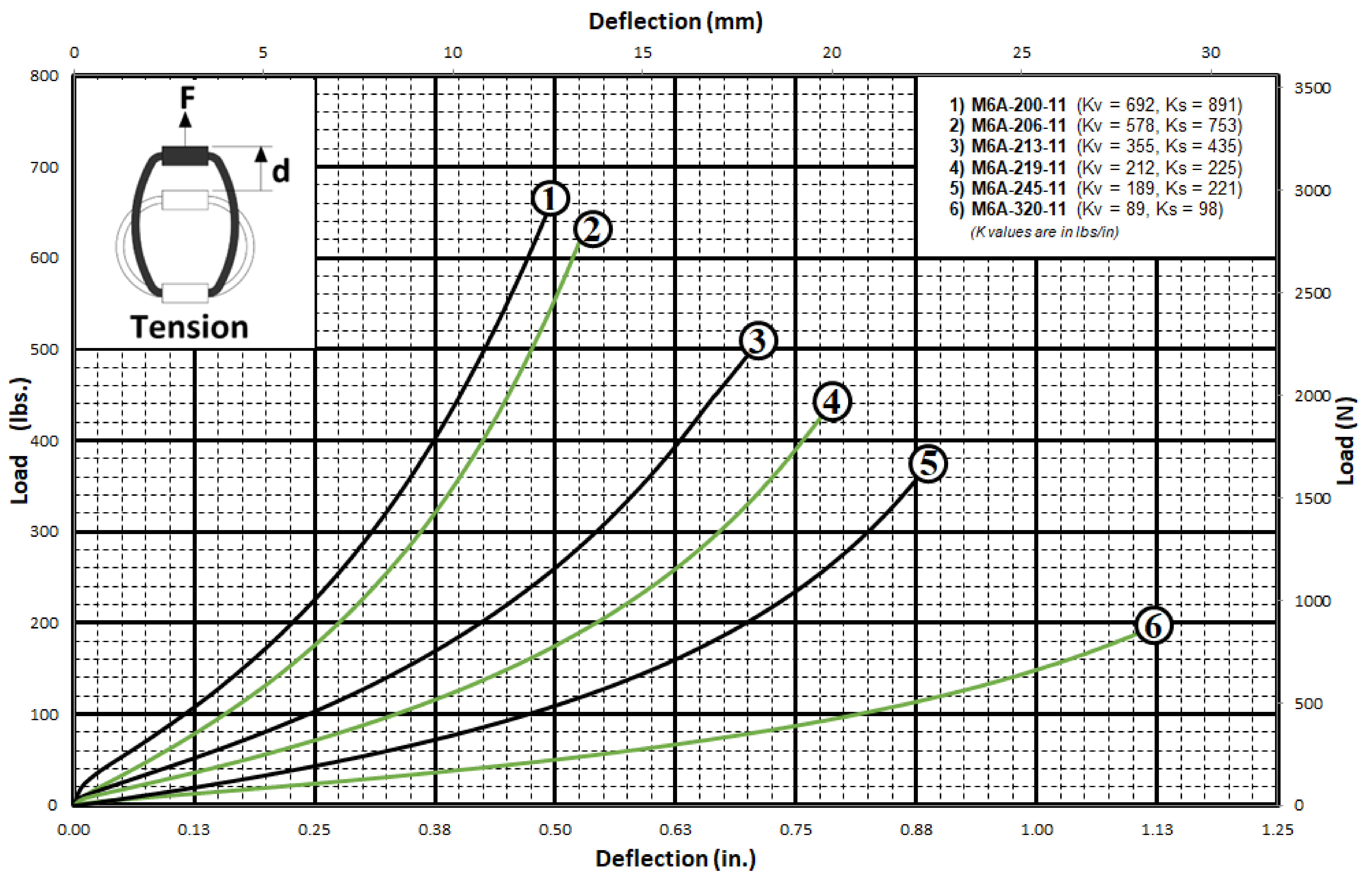
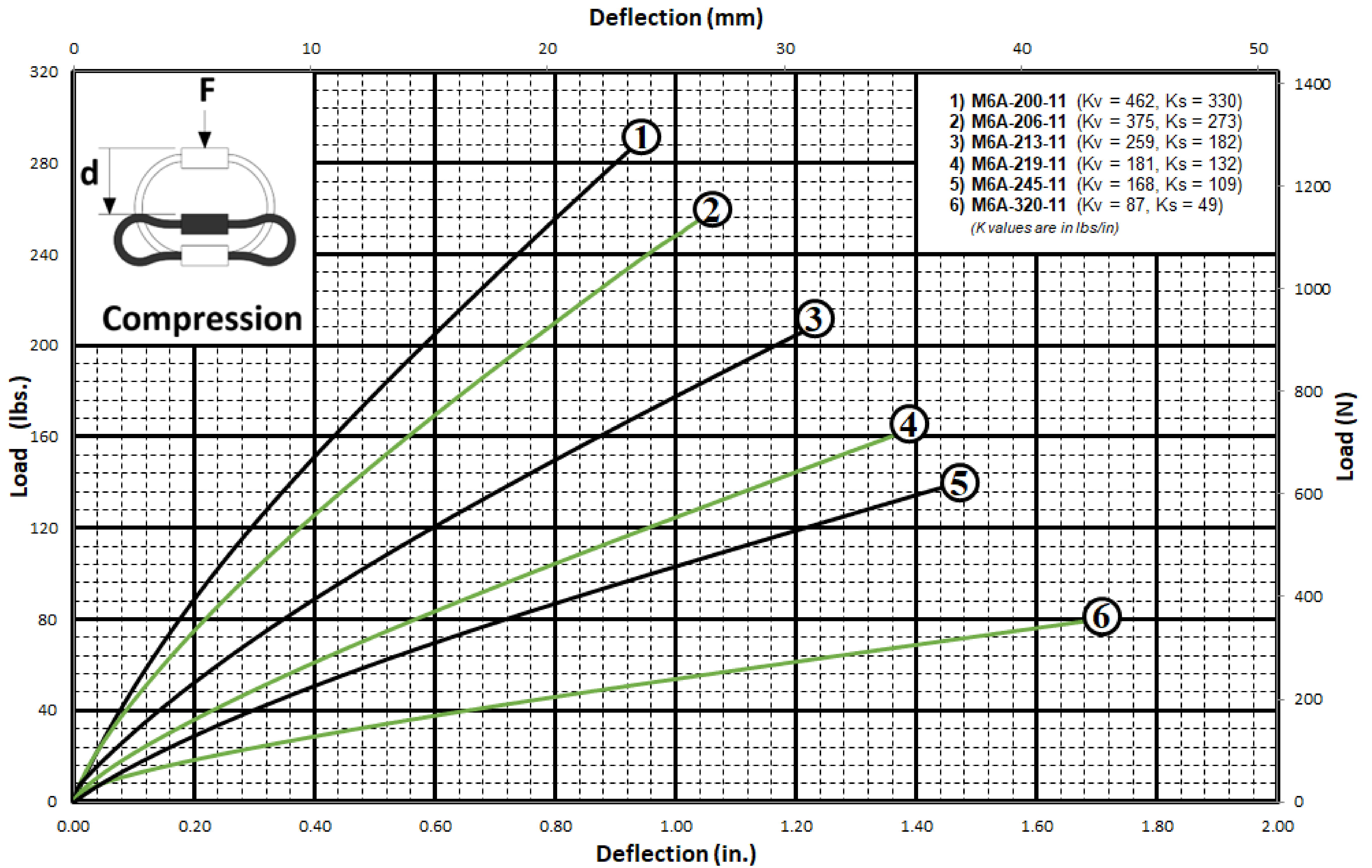

3/16" DIAMETER CABLE

HELICAL ISOLATOR

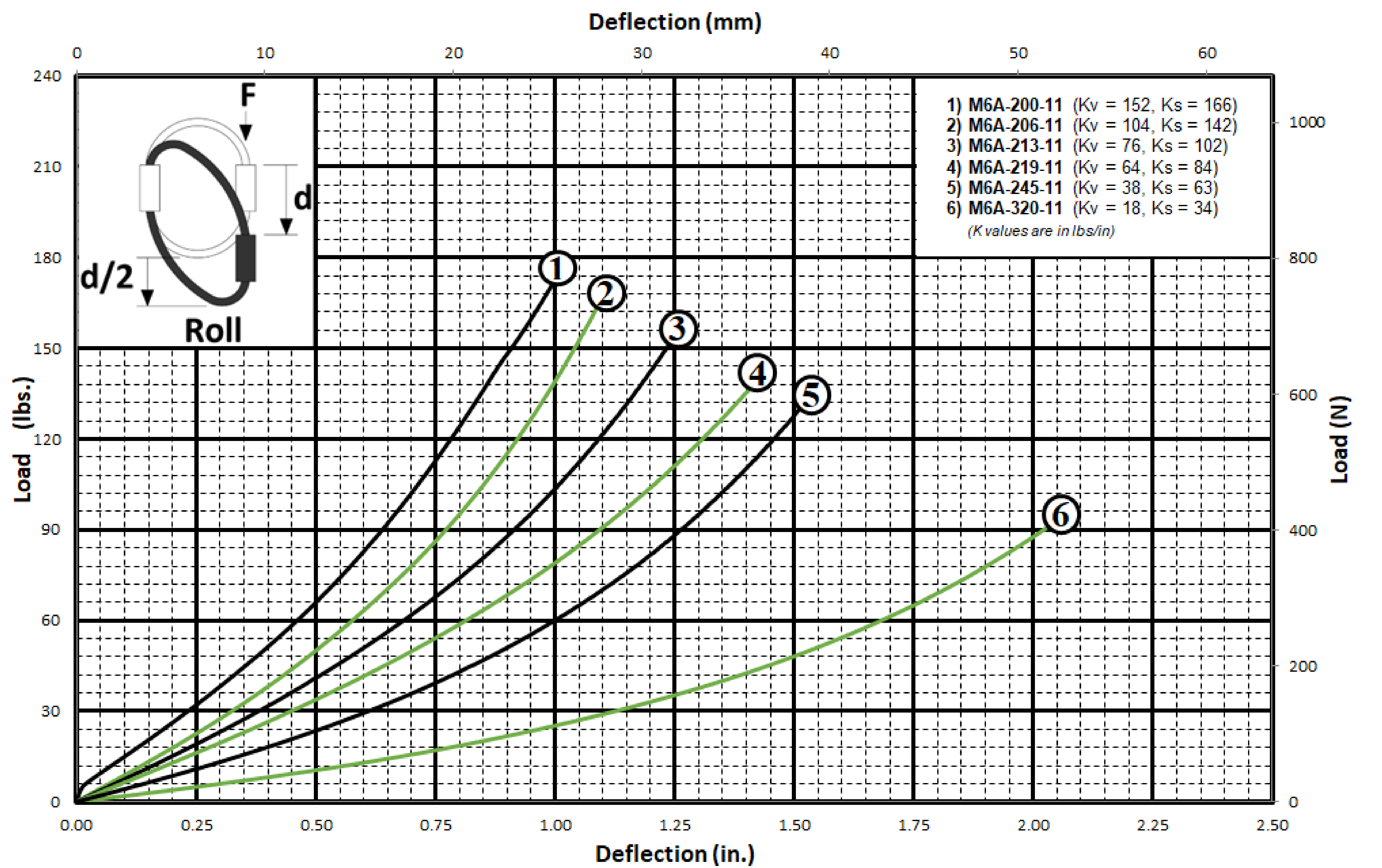
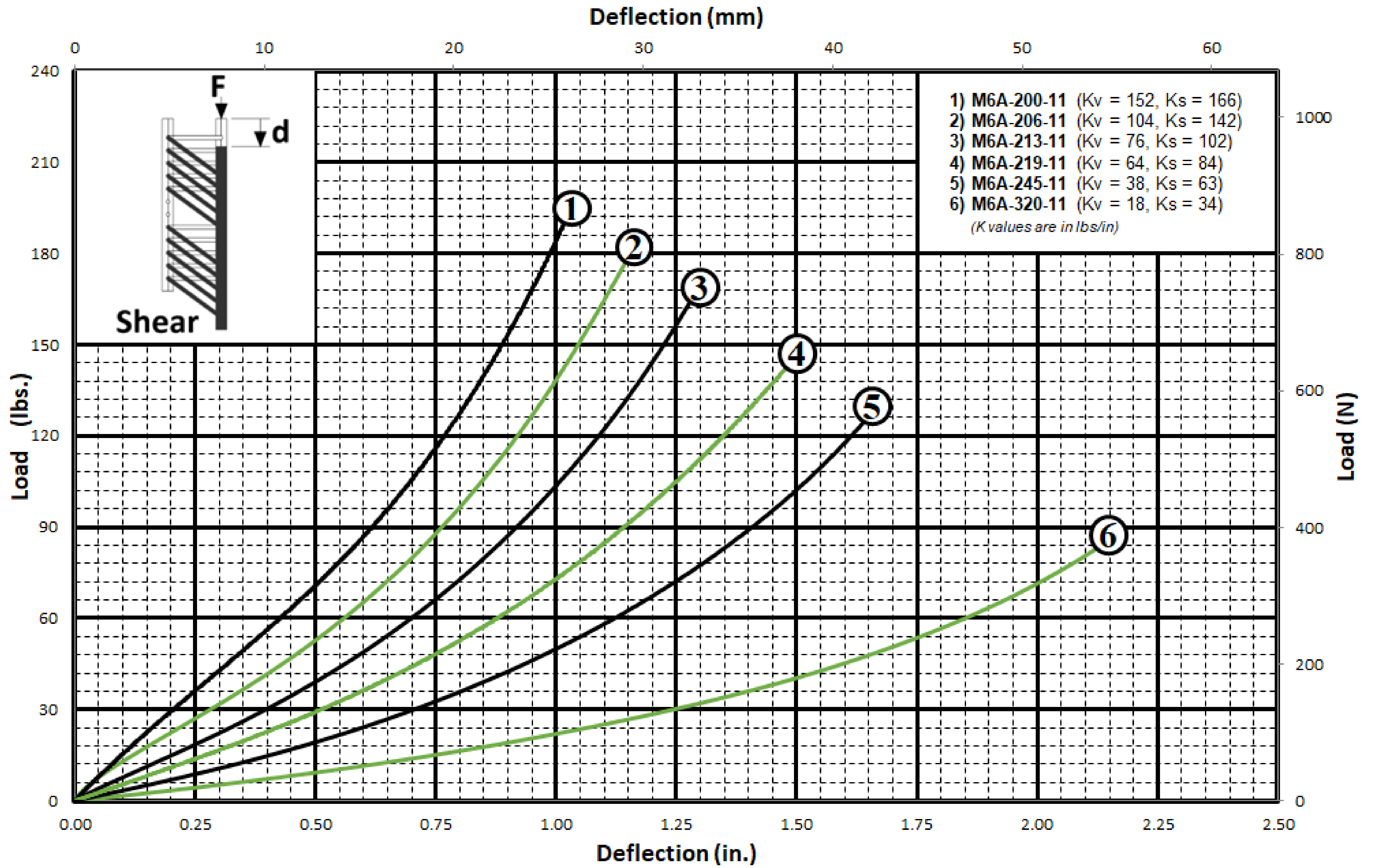

3/16" DIAMETER CABLE

HELICAL ISOLATOR

